

Volume 24, No. 3, Pages 545–716 September 2008 ISSN 0176-2680



European Journal of POLITICAL ECONOMY

Editors:
JAKOB DE HAAN
ARYE L. HILLMAN
HEINRICH W. URSPRUNG

**Symposium and
Book Review Editor:**
WARREN YOUNG

Editorial Board:
TOKE AIDT
MICHAEL BEENSTOCK
HELGE BERGER
TIMOTHY BESLEY
KEN G. BINMORE
FRIEDRICH BREYER
JAMES BUCHANAN
ROGER CONGLETON
CASPER DEVRIES
RICHARD DISNEY
SYLVESTER C.W. EIJFFINGER
LARS FELD
VINCENTO GALASSO
MICHELLE GARFINKEL
MARK GRADSTEIN
GENE GROSSMAN
HANS-PETER GRUNER
SANJEEV GUPTA
JEAN G.J. HINDRIKS
MURAT IYIGUN
GEBHARD KIRCHGASSNER
KAJ KONRAD
NGO VAN LONG
WOLFGANG MAYER
PIERRE-GUILAUME MEON
BRANKO MILANOVIC
DENNIS MUELLER
BILIN NEYAPTI
HANNU NURMI
MARTIN PALDAM
ABUZER PINAR
MARTA REYNAL-QUEROL
DENNIS J. SNOWER
JAN-EGBERT STURM
OTTO H. SWANK
GEORGE TRIDIMAS
FRANTISEK TURNOVEC
JEAN-ROBERT TYRAN
THIERRY VERDIER

CONTENTS

Research papers

T.S. Aidt and A.L. Hillman, Enduring rents	545
S. Bandyopadhyay and M.P. Oak, Coalition governments in a model of parliamentary democracy	554
A. Kappeler and T. Väilä, Fiscal federalism and the composition of public investment in Europe	562
C. Wunder, J. Schwarze, G. Krug and B. Herzog, Welfare effects of the euro cash changeover	571
A.J.G. Brown, J.M. Orszag and D.J. Snower, Unemployment accounts and employment incentives	587
K. Matthews, P. Minford and R. Naraidoo, Vicious and virtuous circles – The political economy of unemployment in interwar UK and USA	605
B. Delfains and D. Demougin, Legal competition, political process and irreversible investment decisions	615
F. Miguet, Voting about immigration policy: What does the Swiss experience tell us?	628
M.K. Justesen, The effect of economic freedom on growth revisited: New evidence on causality from a panel of countries 1970–1999	642
J. Younas, Motivation for bilateral aid allocation: Altruism or trade benefits	661
M. Daumal, Federalism, separatism and international trade	675
A. Lehtinen, The welfare consequences of strategic behaviour under approval and plurality voting	688

Commentary

V. Tanzi, The future of fiscal federalism	705
---	-----

Book review

E. Davar, <i>Walrasian Economics</i>	713
--------------------------------------	-----

This article appeared in a journal published by Elsevier. The attached copy is furnished to the author for internal non-commercial research and education use, including for instruction at the authors institution and sharing with colleagues.

Other uses, including reproduction and distribution, or selling or licensing copies, or posting to personal, institutional or third party websites are prohibited.

In most cases authors are permitted to post their version of the article (e.g. in Word or Tex form) to their personal website or institutional repository. Authors requiring further information regarding Elsevier's archiving and manuscript policies are encouraged to visit:

<http://www.elsevier.com/copyright>

Contents lists available at [ScienceDirect](http://www.sciencedirect.com)

European Journal of Political Economy

journal homepage: www.elsevier.com/locate/ejpe

Enduring rents

Toke S. Aidt^{a,*}, Arye L. Hillman^b^a Faculty of Economics, University of Cambridge, Cambridge CB39DD, UK^b Department of Economics, Bar-Ilan University, 52900 Ramat-Gan, Israel

ARTICLE INFO

Article history:

Received 6 June 2007

Received in revised form 18 March 2008

Accepted 18 April 2008

Available online 7 May 2008

JEL classification:

D72

Keywords:

Rent seeking

Contests

Rent dissipation

Deregulation

Liberalization

Commitment

ABSTRACT

Rent seeking is often studied with reference to a contemporaneous rent evaluated at a point in time. We study the social cost of rent seeking when rents endure over time, but may have to be re-contested because of imperfect rent protection, or may disappear because of deregulation. The present value of a contested rent measures the social cost of rent seeking, irrespective of imperfect rent protection and the prospect of deregulation. Rent seeking is discouraged by the inability of governments to commit to protect rents and by their inability to commit to rent-generating regulations and policies. Moreover, lasting deregulation can preempt a substantial fraction of the potential rent seeking cost.

© 2008 Elsevier B.V. All rights reserved.

1. Introduction

The focal question in the study of rent seeking concerns the magnitude of the social loss when resources are unproductively used in contesting rents. Answers are not straight-forward because of the absence of empirical observations on resources used in rent seeking. The approach taken has been to attempt to infer the value of social losses from observed values of rents available to be contested. Initial studies pointing out the importance of rent seeking simply presumed complete rent dissipation and so took the value of observed rents to measure social losses of rent seeking (Tullock, 1967; Posner, 1975; Krueger, 1974; Cowling and Mueller, 1978). With competitive free entry into contests and risk neutrality, rent dissipation is indeed complete (Hillman and Katz, 1984). Rent dissipation is also complete in strategic contests when the rent seeking contest takes the form of an all-pay auction (Hillman and Samet, 1987; Baye et al., 1996). If rent dissipation is complete, observed values of monopoly profits or protectionist rents can be added to the Harberger deadweight losses of resource misallocation to establish the complete social costs of rent creation. Likewise, complete social costs can be computed from observed rents from regulation of industry, assignment of budgetary revenue, and personal benefits from political appointment.

The numerous studies of contestability of rents have typically investigated rent dissipation as if rents were created, contested, and dissipated at the same point in time.¹ Rents however often endure over time. At the same time, rights to durable rents are in general not everlasting. Rather, rents may be re-contested in the future. The rents themselves also need not persist indefinitely. Deregulation, liberalization, or reform of the government bureaucracy can eliminate rents, although after elimination a rent may be recreated at some future date. Rent seekers can be expected to be aware that rights to rents are imperfectly protected and that future policies may temporarily or permanently eliminate rents.

* Corresponding author. Tel.: +44 1223 335231; fax: +44 1223 335475.

E-mail address: tsa23@econ.cam.ac.uk (T.S. Aidt).

¹ See the overview by Congleton et al. (2008a) and the papers contained in Congleton et al. (2008b).

In this paper, we study rents that endure over time. We consider how imperfect rent protection and the possibility that rents may be eliminated and recreated in the future affect the social cost of rent seeking. We also consider how much of the social cost of rent seeking can be preempted by future institutional or policy change that allows permanent elimination of rents.

When future rights to rents are imperfectly protected and rents are not assured to persist, the value of a rent is discounted by the likelihood that the rent may need to be re-contested. Rent dissipation at the time at which the rent is initially created is consequently less than the present value of the rent. Evaluation of rent dissipation therefore requires recognition that rights to rents may only be imperfectly protected and that rents, rather than persisting indefinitely, may be temporarily or permanently eliminated by future deregulation or liberalization. We introduce these time-related considerations into a model of rent seeking. We show that the present value of a rent at the time when a rent is created nonetheless measures total social cost due to creation of a rent. Rent dissipation becomes complete over the course of time as rents are re-contested.

If rights to rents were perfectly protected and rents were to persist indefinitely, the initial (and only) contest would evidently be for the present value of the indefinitely retained rent. Rents would then be contested and dissipated only at the time of initial creation. In that case, future rents are but transfers. As noted by Tullock (1971), transfers that are not contestable have no social cost. With full protection of future rights to rents, resources used in rent seeking are then entirely sunk costs and cannot be affected by future deregulation or liberalization. With contemporaneous deadweight costs typically small and all social costs of rent seeking already incurred in the past, the basis is provided for a presumption of “disinterest in deregulation” (McCormick et al., 1984).²

Imperfect rent protection and the risk of elimination of rents, however, create prospects of social gain from deregulation and other liberalizing policy change. The degree of rent protection and promises made by governments not to deregulate in the future are attributes of political institutions. They reflect abilities of governments to commit. When rents endure over time, there are social benefits from a government's inability to commit not to allow a rent to be re-contested or not to eliminate rents in the future. When rights to rents are imperfectly protected and there is no assurance that rents will not disappear, we show that substantial parts of the potential rent seeking cost are preempted by future institutional reforms that do indeed permanently eliminate rents. We stress that persisting rents are not irrelevant for social loss after the rents have been created. Rather, consequences for social loss persist over time, as do consequences for social gain from elimination of rents.

Section 2 introduces the model. Section 3 shows that, with imperfect rent protection and a risk of rent elimination, the present value of a rent at the time of creation nonetheless is the measure of social loss due to rent seeking. In other words, rent dissipation does not depend on either of these imperfections. Section 4 analyzes the benefits of lasting deregulation. Section 5 introduces a specific class of contest success functions. A link is established between imperfect rent protection and the degree of under-dissipation for certain contest success functions. Concluding remarks are in Section 6.

2. The model

We consider an economy with n risk neutral agents who compete to obtain a rent. The value of the rent is π per period and the same for all agents. The probability that agent i wins the rent if a contest takes place at time t is

$$q_{it} = q(y_{t1}, \dots, y_{ti}, \dots, y_{tn}), \quad (1)$$

which is increasing in the resources used by agent i , y_{ti} , and decreasing in the resources used by other agents. The rent seeking contest takes place though discrete time $t=0, 1, 2, 3, \dots, \infty$. The future is discounted with the discount factor $\beta \in (0, 1)$.

The rent itself is enduring, but the property rights to the rent are insecure. This can be so for many reasons. For example, current governments cannot fully commit not to withdraw privileges in the future, nor can they tie the hands of future governments. To capture this, we assume that there is a probability p that the winner of the rent (called the incumbent) might lose the rent in subsequent periods. We interpret p as a measure of rent protection: if $p=1$, the rent is fully protected and the winner of the rent in the first period has rights to it forever; if $p=0$, the rent is not protected at all and is only won for one period at the time. An incumbent may lose a rent won in the past for two main reasons. Firstly, the government, which initially created the rent, may want to orchestrate a new contest to reassign the rent (Gradstein and Konrad, 1999). Secondly, the government may eliminate the rent all together, e.g., through deregulation of monopolies, through liberalization of trade or reform of the government bureaucracy. This would happen, for example, if a new government comes to power and deregulates an industry, although the decision may be reversed by some future government. Specifically, in periods after the incumbent has lost the rights to the rent, a new contest is orchestrated with probability $1-z$, while with probability z , the rent is eliminated for that period and thus not contestable. A higher z makes it less likely that the rent can be re-contested in periods after it is lost and liberalization, deregulation or, more generally, rent-destroying reforms are more enduring and less likely to be reversed. If $z=1$, the loss of the rent is followed by permanent deregulation and the rent never again becomes contestable; if $z=0$, the loss of the rent is followed immediately by a new contest and effectively no deregulation or liberalization is taking place; the rent is just reassigned. Alternatively, we can interpret z as an inverse measure of the government's commitment to rent-generating regulations and policies. The two parameters p and z are attributes of institutions that are common knowledge and reflect abilities of governments (understood as the creators of contestable rents) to commit.

The structure of the model is sketched in Fig. 1 for the first three periods. When the rent is initially created in period 0, a contest takes place and the state of the economy is C (contest). After that, it is revealed whether the rent is protected or not. If it is, the

² While deregulation or other policy reform in these circumstances could not recoup past sunk rent seeking losses, there would, of course, be distributional consequences of deregulation or liberalization (Cherkas et al., 1986; Crew and Rowley, 1988).

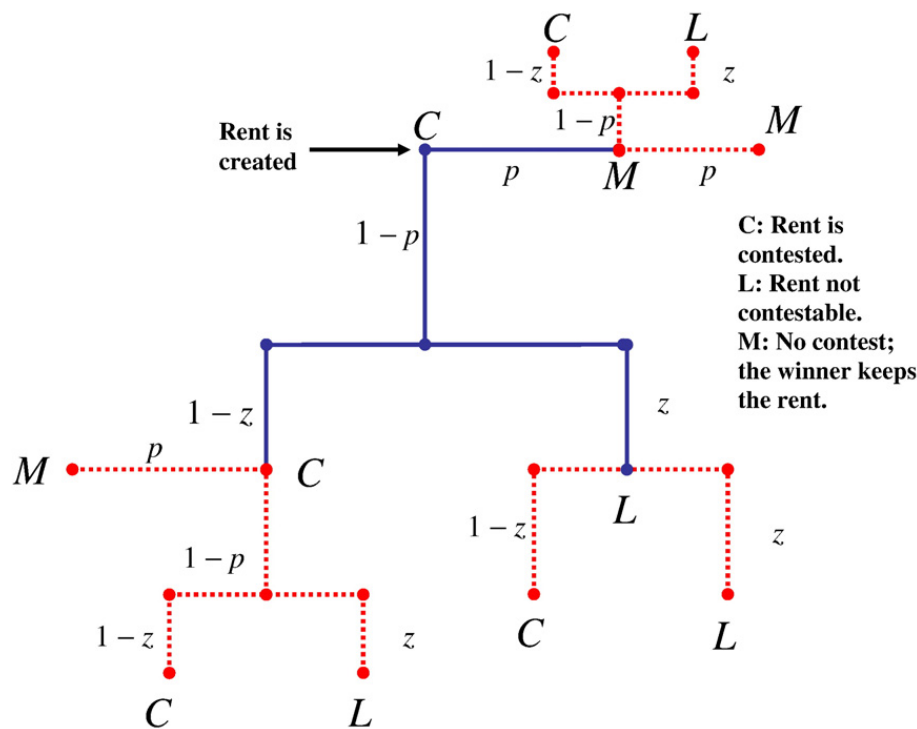

Fig. 1. The structure of the model.

winner – the incumbent – keeps the rent and the economy is in state *M* (monopoly) in period 1 and no contest takes place. If not, the rent is either reassigned through a new contest and the economy is in state *C* or the rent is deregulated and is not contestable and the economy is in state *L* (liberalization). The possible transitions from period 1 to 2 are indicated with dotted lines. We note that if the state is *L* at time 1, then the rent either continues to be deregulated (and the economy is in state *L* in period 2) or the rent is recreated and a new contest takes place in period 2.

Our main question is: does imperfect rent protection ($p < 1$) and/or the government's inability to commit to rent-generating regulations and policies ($z > 0$) lead to under-dissipation of the rent? That is, does uncertainty about future rights to the rent reduce the social cost associated with its initial creation? While this is the primary question, it is also of interest to study the total rent seeking cost. Ultimately, rent seeking is costly because resources are being used unproductively. This reduces the productive base of an economy and the scarce resources invested in winning rents reduce national income. The real cost of this reallocation of resources from productive to unproductive activities depends on the total rent seeking cost. In models in which the value of the contested rent is fixed, the dissipation rate and the total resources going into rent seeking are normally two sides of the same coin.³ However, in our baseline model, variations in p and z affect the total rent seeking cost *independently* of the dissipation rate. It is, therefore, of interest to inquire how these factors increase or decrease the total social cost of rent seeking, and to ask how much of the total social cost of rent seeking, if any, can be preempted through permanent deregulation at some point in time after the rent has first been created.

3. Rent dissipation and the total cost of rent seeking

As long as rent seeking persists, there is a social loss due to contestability of the rent. Resource use in quest of the rent and rent dissipation cease, as pointed out by Congleton (1980), only when a successful winner of the contest is announced. However, rights to a rent that has been won in the past may not be secure in the future ($p < 1$). Moreover, the rent may altogether disappear, perhaps to return at some further point in time ($z > 0$). As noted above, we think of z as a measure of the government's inability to commit not to deregulate, while we interpret p as a measure of the security of the property rights to rents won in the past.

The model has three states of the world: $s_t \in \{M, C, L\}$. *M* is the state where the rent is maintained by the incumbent and is uncontested; *C* is the state where the incumbent loses the right to the rent but the rent is re-contested immediately; and *L* is the state where the incumbent loses the right to the rent and the rent disappears and so is not contestable in that period. We note that the contenders for the rent face three sources of uncertainty. There is uncertainty because of imperfect rent protection, as the winner of the rent in a given period will only keep the rent in the next and subsequent periods with probability p . Furthermore, whenever rights to the rent are lost, there is a risk (z) that a new contest will not take place and the rent is not contestable, but if a new contest does take place, contenders are faced with uncertainty regarding the outcome.

³ Aidt (2002, 2003b) discuss this point in more detail and show what happens when the size of the rent depends on the investments made by the contenders.

To characterize the individually optimal rent seeking strategy of contender i , we construct the relevant value functions and look for Nash equilibria. First, suppose that $s_t=L$. Since no contest takes place in this state and any preexisting rights to the rent have been lost, the value function of contender i is

$$V_t^i(L) = \beta \left[zV_{t+1}^i(L) + (1-z)V_{t+1}^i(C) \right], \tag{2}$$

where $V_{t+1}^i(C)$ is the continuation value starting from a state where a contest takes place.

Next, suppose that $s_t=M$. We distinguish between the continuation value of the winner of the previous contest (w) and that of a contender who lost the previous contest (l). The value function for the winner is

$$V_t^{wi}(M) = \pi + \beta \left[pV_{t+1}^{wi}(M) + (1-p) \left[zV_{t+1}^i(L) + (1-z)V_{t+1}^i(C) \right] \right]. \tag{3}$$

The winner is successful in obtaining the rent in the current period and keeps it without a contest in the next period with probability p . With probability $1-p$, the winner loses rights to the rent. In this case, the rent disappears with probability z and no contest takes place, but, with probability $1-z$, he or she competes again in an attempt to re-secure the rent. The value function for a representative loser is

$$V_t^{li}(M) = \beta \left[pV_{t+1}^{li}(M) + (1-p) \left[zV_{t+1}^i(L) + (1-z)V_{t+1}^i(C) \right] \right]. \tag{4}$$

Each loser of a contest will with probability p continue being a loser next period simply because the rent stays with the incumbent. With probability $(1-p)(1-z)$, the rent becomes contestable again in the subsequent period and each (past) loser can compete to obtain it; with probability $z(1-p)$, the rent does not become contestable in the subsequent period.

When the state of the world is $s_t=C$ and a contest takes place, all contenders face an identical problem.⁴ We can write the value function as:

$$V_t^i(C) = q_{ti}\pi - y_{ti} + q_{ti}\beta \left\{ pV_{t+1}^{wi}(M) + (1-p) \left[zV_{t+1}^i(L) + (1-z)V_{t+1}^i(C) \right] \right\} \\ + (1-q_{ti})\beta \left\{ pV_{t+1}^{li}(M) + (1-p) \left[zV_{t+1}^i(L) + (1-z)V_{t+1}^i(C) \right] \right\}. \tag{5}$$

In the current period, the expected gain is $q_{ti}\pi - y_{ti}$ where y_{ti} represents the rent seeking expenditure by contender i and $q_{ti}\pi$ is the within-period expected value of winning the rent. The future payoff depends on whether or not a contender has won the contest. If a contender wins, which occurs with probability q_{ti} , the rent is either kept or lost in the next period. A contender who lost the contest in period t , which happens with probability $1-q_{ti}$, will continue to be a loser in the next period if the rent is protected, or is given a new chance to compete if the current incumbent loses rights to the rent, but only with probability $(1-z)$.

We can rewrite Eq. (5) to obtain

$$V_t^i(C) = q_{ti}\pi - y_{ti} + q_{ti}\beta p \left[V_{t+1}^{wi}(M) - V_{t+1}^{li}(M) \right] + K, \tag{6}$$

where $K = \beta(1-p)[zV_{t+1}^i(L) + (1-z)V_{t+1}^i(C)] + \beta p V_{t+1}^{li}(M)$ and is independent of the investments made by the contenders in period t . The difference between the continuation value of a winner and a loser in state M at time $t+j$ is

$$V_{t+j}^{wi}(M) - V_{t+j}^{li}(M) = \pi + \beta p \left(V_{t+j+1}^{wi}(M) - V_{t+j+1}^{li}(M) \right). \tag{7}$$

Forward substitution yields that

$$V_{t+j}^{wi}(M) - V_{t+j}^{li}(M) = \sum_{k=0}^{\infty} (\beta p)^k \pi = \frac{\pi}{1-\beta p}. \tag{8}$$

Substituting this into Eq. (6), we obtain that the continuation value of a contender in state C can be written as

$$V_t^i(C) = q_{ti} \frac{\pi}{1-\beta p} - y_{ti} + K. \tag{9}$$

A Nash equilibrium of the contest played in state C at time t is defined as a vector of resources $\{y_{ti}^*\}_{i=1}^n$ to be invested such that for each contender i , $y_{ti}^* = \max_{y_{ti}} V_{t+1}^i(C; y_{-ti}^*)$, where y_{-ti}^* denotes the vector of investments of the $n-1$ other contenders. We assume that there exists a unique Nash equilibrium in each contest and that the corresponding equilibrium strategies are played each time the state is C . Given that, Eq. (9) implies that $q_{ti} = q_i$ and $y_{ti} = y_i$ all t such that $s_t=C$ and that the equilibrium path of the economy must be stationary for any given contest success function. Using this observation, Eqs. (2), (3) and (4) can be rewritten as

$$V^i(L) = \frac{(1-z)\beta V^i(C)}{1-z\beta} \tag{10}$$

⁴ We treat contenders symmetrically in each contest. An alternative is to assume that the winner of the contest may have to fight again in the future to protect his rent, while past losers do not contest the rent in the future (Stephan and Ursprung, 1998).

$$V^{wi}(M) = \frac{\pi + \beta(1-p)(1-z) \frac{V^i(C)}{1-z\beta}}{1-\beta p} \quad (11)$$

$$V^{li}(M) = \frac{\beta(1-p)(1-z) \frac{V^i(C)}{1-z\beta}}{1-\beta p} \quad (12)$$

We can use these expressions to solve Eq. (9) to obtain

$$V^i(C) = \frac{(1-z\beta)(1-\beta p)}{(1-\beta zp)(1-\beta)} \left(q_i \frac{\pi}{1-\beta p} - y_i \right). \quad (13)$$

It is well-known that the degree of rent dissipation depends on the particular attributes of the contest, including the properties of the contest success function, risk aversion, and the number of contenders. To isolate the effects of imperfect rent protection on the extent of rent dissipation from all these other influences, we begin by assuming conditions such that one dollar of assured rent at a point in time attracts one dollar of resources, i.e., the expected present value of the rent, $\frac{\pi}{1-\beta p}$, is fully dissipated in each contest.⁵ We consider a specific class of contest success function in Section 5 and discuss how p and z might reinforce or weaken other reasons for under-dissipation. The value of the rent in each contest is larger than π unless the rights to the rent are lost with certainty in the period after the rent is won ($p=0$). If rent protection is perfect ($p=1$), the contenders effectively compete for the entire present value of the rent in the first period, as proposed by McCormick et al. (1984).

We want to know if imperfect rent protection and the risk that rents become non-contestable lead to under-dissipation of the rent. By assumption, whenever a contest takes place, resources equal to $\frac{\pi}{1-\beta p}$ are used in contesting the rent. Does that, in present value terms, lead to under-dissipation? The answer is, perhaps surprisingly, no.

Proposition 1. Assume that rent dissipation is complete in each contest.

1. The present value of the resources attracted to rent seeking equals the present value of the contestable rent for all p and z .
2. The present value of resources attracted to rent seeking is

$$R(z, p) = \frac{(1-z\beta)\pi}{(1-\beta)(1-\beta pz)} \quad (14)$$

and is increasing in p and decreasing in z .

Proof. Let $R(s_t)$ denote the present value of resources used up by rent seeking in state $s_t \in \{C, M, L\}$. The value of resources entering rent seeking is

$$R(C) = \frac{\pi}{1-\beta p} + p\beta R(M) + \beta(1-p)(1-z)R(C) + \beta(1-p)zR(L), \quad (15)$$

where

$$R(M) = \beta p R(M) + \beta(1-p)(1-z)R(C) + \beta(1-p)zR(L) \quad (16)$$

and

$$R(L) = \beta z R(L) + \beta(1-z)R(C). \quad (17)$$

Solving this system of value functions yields:

$$R(C; z, p) = \frac{(1-z\beta)(1-p\beta)}{(1-\beta)(1-\beta pz)} \frac{\pi}{1-\beta p} = \frac{(1-z\beta)\pi}{(1-\beta)(1-\beta pz)}. \quad (18)$$

Since the rent π may not become contestable immediately after the incumbent's rights to it have been lost, the present value of the rent is not $\frac{\pi}{1-\beta}$ but is calculated as follows. Let $U(R)$ denote the present value of the rent in state $s_t=M$ and $s_t=C$ and let $U(L)$ be the present value in state $s_t=L$. The value of the contestable rent is, therefore,

$$U(R) = \pi + \beta p U(R) + \beta(1-p)(1-z)U(R) + \beta(1-p)zU(L), \quad (19)$$

where

$$U(L) = \beta(1-z)U(R) + \beta z U(L). \quad (20)$$

⁵ See Hillman and Katz (1984), Hillman and Samet (1987) and Baye et al. (1996). There are various reasons for under-dissipation at a point in time: see the survey by Nitzan (1994) and the overviews by Mueller (2003), Hillman (2003), and Congleton et al. (2008a). On the other hand, countervailing behavior or resistance through sabotage in contests can increase rent dissipation (Konrad, 2000).

Solving these equations yields

$$U(R; z, p) = \frac{(1 - z\beta)\pi}{(1 - \beta)(1 - \beta pz)}. \quad (21)$$

So, we conclude that

$$\frac{R(C; z, p)}{U(R; z, p)} = 1 \quad (22)$$

for all p and z . □

We interpret Proposition 1 as a neutrality result: under the assumption that rent dissipation is complete in each contest, neither imperfect protection of enduring rents, nor the risk that rents become non-contestable, affect the rent dissipation rate. That is, irrespective of whether the rent is extremely well-protected or not protected at all, or something in between, the sequence of contests over time initiated by the creation of the rent dissipates the present value of the rent completely.

To see the intuition behind this result, suppose that rents become contestable as soon as they are lost ($z=0$). In each period in which a contest takes place, the contenders spend in total $\frac{\pi}{1-\beta p}$ – the present value of the rent discounted by the probability of keeping the rent in the future. The ex ante probability that a contest takes place in a given period is $1 - p$. Therefore, the present value of the resources spent on rent seeking is $\frac{\pi}{1-\beta} + \beta(1 - p)\frac{\pi}{1-\beta p} + \beta^2(1 - p)\frac{\pi}{1-\beta p} + \dots$. This is precisely equal to the present value of the rent $\frac{\pi}{1-\beta}$ for any p . Hence, in response to imperfect rent protection, contenders spend less than $\frac{\pi}{1-\beta}$ in each contest, as the prospect of keeping the rent is uncertain. However, the part of the present value of the rent that is not dissipated in the first contest will be dissipated eventually in future contests and repeated competition for the rent dissipates the rent completely. In effect, this reflects a trade off between two conflicting forces, which is also considered by Gürtler (2007). On the one hand, the better protected the rent is, the more resource will be invested in rent seeking in each contest. On the other hand, contests become less frequent. In our model, the two effects exactly net out. The proposition shows that this fundamental result continues to hold when there is a risk that rents may not be contestable after they are lost ($z>0$). The reason is that during periods in which the rent is not contestable due to, for example, rent-destroying reforms, resources are not wasted on rent seeking.

While Proposition 1 shows that a government's inability to commit to protect rents and/or to refrain from rent-destroying reforms does not matter for the rent dissipation rate, it is clear that the timing of dissipation is affected by both p and z . The timing pattern has two interesting implications. These are most clearly seen if we, again, assume that $z=0$. First, the degree of rent protection has intergenerational consequences. In particular, if $p=1$ so that commitment to rent protection is perfect, the entire present value of the rent is dissipated in the first period and the social loss is thus borne by the current generation. If $p=0$ and government lacks commitment power, π will be contested and dissipated each period. In this case, the social burden of rent seeking is shared equally among generations. Generally, the more secure are rights to a rent, the more infrequent are the contests and the more is dissipated in each contest. Second, $p<1$ is a reflection of a government's inability to grant lasting property rights to the rents it creates. Commitment to protection of rents may be more difficult in a democracy with frequent government changes and where current governments cannot perfectly tie the hands of future governments⁶ than in authoritarian regimes where rulers may be able to grant privilege more permanently. As a consequence, in authoritarian regimes, we would expect greater contestability at the time rents are created, and a greater burden in terms of rent dissipation at that time. In democracies rent seeking will tend to be more spread out over time. Rent seeking expenditures are resources used unproductively. Insofar as diversion of resources away from productive use in the early stages of development has lasting effects, this observation provides yet another reason why authoritarian societies have failed to develop.⁷ This effect would strengthen, if under authoritarian rule, the size of the rent in future periods were diminished endogenously by high initial levels of rent seeking.⁸

The second part of Proposition 1 shows that the total rent seeking cost depends on p and z . This is because the *present* value of the contestable rent depends on the degree of rent protection and the risk of rent-destroying reforms.⁹ These parameters are intrinsically linked to the nature of political institutions and politicians' ability to make commitments. Two important points can be made. First, political competition makes rents insecure. This is because future governments may re-open or re-orchestrate rent seeking contests and take away privileges bestowed in the past and eliminate policies favoring special interests. Political competition can also be the basis for expectations of rent-destroying reforms, e.g., if a more pro-liberalization government is expected to take office in the future. Political competition thereby reduces the total cost of rent seeking both by making rents less secure (lower p) and by creating expectations of (lasting) rent-destroying reforms (higher z). Second, much economic literature is concerned with inefficiencies that arise because governments cannot commit. Interestingly, when rents endure over time, there are social benefits from a government's inability to commit. The benefits arise because of the inability to commit to protect rents. This makes rent seekers less willing to invest resources to obtain the rent and reduces the overall social cost of rent seeking by reducing the value of the rents to be contested. Likewise, the inability to commit not to attempt to introduce rent-destroying reforms (high z), such as a liberalization of trade or deregulation of monopolies, decreases the social cost of rent seeking.

⁶ See, e.g., Persson and Svensson (1989).

⁷ This, for example, happens if barriers are created to technological adoption (Pareto and Prescott, 2000).

⁸ We thank an anonymous referee for suggesting this possibility and for pointing out that there is less room in a democracy for rent seeking because of better protected property rights.

⁹ We note that the comparative statics results discussed below do not depend on the assumption of full rent dissipation in each contest. They would hold for any contest success function that leads to under-dissipation in each contest as long as the total resources going into rent seeking are an increasing function of the value of the contestable rent.

4. The benefits of lasting deregulation

How much of the total rent seeking cost can be preempted by *lasting* rent-destroying reforms (deregulation)? To answer this question, we define the gain from lasting deregulation (GLD(p)) as the difference between the discounted present value of rent seeking expenditures when there is no commitment to deregulation ($z=0$) and a situation in which deregulation, when it happens, is permanent ($z=1$), relative to the rent-seeking cost without deregulation:

$$GLD(p) = \frac{R(0, p) - R(1, p)}{R(0, p)}, \tag{23}$$

where $R(z, p)$ is given in Eq. (14). We find:

Proposition 2. *The gain from lasting deregulation is*

$$GLD^*(p) = \frac{(1 - p)\beta}{(1 - p\beta)}, \tag{24}$$

which is decreasing in p .

Proof. The proposition follows immediately from Eq. (14). □

A number of consequences follow from proposition 2. First, in societies where rent protection is perfect ($p=1$), the present value of all future rents is dissipated completely in the first period, i.e., when the rent is first created. A rent-seeking loss that is sunk cannot be recouped in any subsequent deregulation. This is the point that was made by McCormick et al. (1984). Second, in societies where rent protection is imperfect, there is, however, a gain from lasting deregulation, as the rent-seeking cost is spread over time and some of it can, in expectation, be recouped if society introduces appropriate institutional reforms. The gain is decreasing in rent protection (p). Accordingly, the incentive to create institutions that allow politicians to commit to lasting deregulation is stronger in societies where politicians cannot protect incumbents' rents very well. Insofar as democracy makes it harder for politicians to commit to rent protection, democratic societies face strong incentives to invest in institutions that allow them to commit to deregulation. To obtain a sense of how much of the potential rent seeking cost can be preempted by lasting deregulation, consider a society in which $\beta=0.9$ and $p=0.5$ such that rents are protected, on average, for 2 years. In this society, the gain from deregulation is about 81%. In contrast, in a society where $p=0.75$ and rents are, on average, protected for 12 years, 69% of rent dissipation can be preempted. Even when $p=0.9$ and rents are protected, on average, for 90 years, the saving is still substantial; just under 50%. Thus, it is only when rents are extremely well protected (p close to 1) that lasting deregulation is of no value in preempting social costs of rent seeking; in all other cases, the prospect of preempting a large fraction of the potential rent seeking cost creates a substantial interest in deregulation. Of course, in addition to the rent-seeking losses preempted, deregulation of monopolies and removal of trade restrictions also preempt deadweight losses.

5. Specific contest success functions and rent protection

In the analysis above, we did not specify the contest success function, but assumed that rent dissipation would be complete in each contest. The neutrality result – that the degree of rent dissipation is independent of p and z – reported in Proposition 1 would, however, hold for any contest success function for which the contenders' equilibrium investments are linear functions of the value of the rent $\frac{\pi}{1-\beta p}$ irrespective of whether dissipation is complete in each contest or not. Conversely, it follows from the analysis of the design of contests with short and long-run contracts in Gürtler (2007) that the result does *not* hold for contest success functions for which the equilibrium investments are non-linear functions of the value of the rent.

To see this, suppose, as in Gürtler (2007), that the contest success function takes the following form:

$$q_{ti} = \frac{f(y_{ti})}{\sum_{i=1}^n f(y_{ti})} \text{ if } \sum_{i=1}^n f(y_{ti}) > 0 \tag{25}$$

and $q_{ti} = \frac{1}{n}$ otherwise. The function f is strictly increasing.¹⁰ Applying this contest success function, it is easy to verify that the total rent-seeking expenditure wasted each time the state is C is

$$nh \left(\frac{n-1}{n^2} \frac{\pi}{1-\beta p} \right) \tag{26}$$

where $h(\cdot) = (f/f')^{-1}(\cdot)$ is a strictly increasing function. The total value of the rent is still given by Eq. (21). The present value of resources used in rent seeking can be found by substituting $nh \left(\frac{n-1}{n^2} \frac{\pi}{1-\beta p} \right)$ for $\frac{\pi}{1-\beta p}$ in Eq. (18). Accordingly, we find that the dissipation rate is

$$\frac{nh \left(\frac{n-1}{n^2} \frac{\pi}{1-\beta p} \right)}{\frac{\pi}{1-\beta p}}. \tag{27}$$

¹⁰ To insure a unique interior solution, it is sufficient to assume that $f'' \sum_{i=1}^N f(\cdot) - (f'(\cdot))^2 < 0$. This condition implies that $f'' \sum_{i=1}^N f(\cdot) - 2(f'(\cdot))^2 < 0$.

From this equation, we notice that, irrespective of the properties of h , the rent dissipation rate is always independent of z . On the other hand, it is only independent of p when h is linear.¹¹ In particular, taking the derivative with respect to p yields

$$\frac{n\beta}{\pi} \left[h'(\cdot) \frac{n-1}{n^2} \frac{\pi}{1-\beta p} - h\left(\frac{n-1}{n^2} \frac{\pi}{1-\beta p}\right) \right]. \quad (28)$$

This derivative is negative (positive) if the function h is strictly concave (strictly convex). In other words, if h is strictly concave (strictly convex), better protection of rents – an increase in p – is associated with a decrease (an increase) in the rent dissipation rate.¹² This analysis shows that rent protection – the extent to which rents endure – may in specific circumstances affect the rent dissipation rate. This happens when the contest success function is such that the total rent seeking cost is a non-linear function of the value of the rent. In these cases, the degree of rent protection interacts with pre-existing reasons for under-dissipation of rents and may reinforce or weaken these reasons. It is also interesting to notice that an increase in p may reduce the rent dissipation rate, but at the same time increase the total rent-seeking cost. This happens when the function h is strictly concave.

6. Conclusions

Evaluations of social costs of rent seeking only at a point in time are appropriate if rents do not endure – or if rents do endure, but need to be continually re-contested. Rents are, however, often both enduring and re-contestable. Rents may also disappear in the future because of changes in government policies. As a consequence, rents are not, in general, completely dissipated at the time at which they are created. Yet, as we have shown, *the present value of a contested rent* remains the correct measure of social loss due to rent seeking. Since rent seeking activities are often unobserved while the value of rents can be measured, this is a useful identification principle. We have also shown that the total rent-seeking cost is large in societies where rents are well protected and in which the government cannot commit to lasting rent-eliminating reforms. Institutional reforms that allow governments to commit to lasting deregulation or other rent-eliminating reforms can, with imperfect rent protection, preempt a substantial part of the potential social cost of rent seeking. The cost of rent seeking that is preempted supplements the social gains from deregulation through saved deadweight losses.

A further interesting question concerns institutional design. Different institutional arrangements empower politicians and governments with different abilities to protect the rents of incumbents and to keep rent-creating legislation in place.¹³ The choice of institutions, of course, depends on the objective function of the designer. Under the assumption that the government captures a fraction of the resources used in rent seeking, we may note the “optimal” institutional choice is to commit to full rent protection ($p=1$) as this maximizes contemporary resource capture. Institutions that limit political competition are a means of such commitment. Absence of political competition in low-income countries where corruption is extensive is therefore consistent with high rent extraction and rent capture at the time at which rents are created.¹⁴

Acknowledgements

We would like to thank Heinrich W. Ursprung, Mark Gradstein, two anonymous referees and the participants in the Silvaplana 2006 workshop on political economy for constructive and helpful comments. The work for this paper started when Toke S. Aidt visited the Department of Economics at Bar-Ilan University in 2006. The hospitality of the department is much appreciated.

References

- Aidt, T.S., 2002. Strategic political participation and redistribution. *Economics and Politics* 14, 19–40.
- Aidt, T.S., 2003a. Economic analysis of corruption: A survey. *Economic Journal* 113, F632–F652.
- Aidt, T.S., 2003b. Redistribution and deadweight costs: The role of political competition. *European Journal of Political Economy* 19, 205–226.
- Baye, M.R., Kovenock, D., de Vries, C.G., 1996. The all-pay auction with complete information. *Economic Theory* 8, 362–380.
- Cherkes, M., Friedman, J., Spivak, A., 1986. The disinterest in deregulation: Comment. *American Economic Review* 86, 559–563.
- Congleton, R.D., 1980. Competitive process, competitive waste, and institutions. In: Buchanan, J.M., Tollison, R.D., Tullock, G. (Eds.), *Toward a Theory of the Rent-seeking Society*. Texas A&M University Press, College Station, pp. 153–179. Reprinted in Congleton et al., 2008b.
- Congleton, R.D., Hillman, A.L., Konrad, K.A., 2008a. Forty years of research on rent seeking: an overview. In: Congleton, R.D. (Ed.), *The Theory of Rent Seeking: Forty Years of Research Volume 1 Theory. Volume 2, Applications*. Springer, Berlin.
- Congleton, R.D., Hillman, A.L., Konrad, K.A. (Eds.), 2008b. *Forty Years of Research on Rent Seeking. Volume 1 – The Theory of Rent seeking. Volume 2 – Applications: Rent Seeking in Practice*. Springer, Berlin.
- Cowling, K., Mueller, D.C., 1978. The social cost of monopoly power. *Economic Journal* 88, 727–748 Reprinted in Congleton et al., 2008b.
- Crew, M.A., Rowley, C.K., 1988. Dispelling the disinterest in regulation. In: Rowley, C.K., Tollison, R.D., Tullock, G. (Eds.), *The Political Economy of Rent Seeking*. Kluwer Academic Publishers, Boston, pp. 163–178.
- Gradstein, M., 2004. Governance and growth. *Journal of Development Economics* 73, 505–518.
- Gradstein, M., Konrad, K.A., 1999. Orchestrating rent-seeking contests. *Economic Journal* 109, 536–545 Reprinted in Congleton et al., 2008b.
- Gürtler, O., 2007. Short-term or long-term contract? A rent-seeking perspective. *Governance and Efficiency of Economic Systems Discussion Paper no. 208*. University of Bonn, Germany.
- Hillman, A.L., 2003. *Public Finance and Public Policy*. Cambridge University Press, New York.

¹¹ In the special case with $n \rightarrow \infty$ (which implies complete dissipation in each contest), we get that the rent dissipation rate is 1.

¹² Gürtler (2007) explores the implications of this logic for the optimal choice of contract length. He concludes that contracts should be short (rents should not endure) if the contest success function is strictly convex and long (rents should be allowed to endure) if it is strictly concave.

¹³ See Gradstein (2004) for an interesting analysis of how and why institutions that protect property rights emerge.

¹⁴ See Aidt (2003a) for a discussion of the links between political competition and corruption.

- Hillman, A.L., Katz, E., 1984. Risk-averse rent seekers and the social cost of monopoly power. *Economic Journal* 94, 104–110 Reprinted in Congleton et al., 2008a.
- Hillman, A.L., Samet, D., 1987. Dissipation of contestable rents by small numbers of contenders. *Public Choice* 54, 63–82 Reprinted in Congleton et al., 2008b.
- Konrad, K.A., 2000. Sabotage in rent-seeking contests. *Journal of Law, Economics, and Organization* 16, 155–165 Reprinted in Congleton et al., 2008b.
- Krueger, A.O., 1974. The political economy of the rent-seeking society. *American Economic Review* 64, 291–303 Reprinted in Congleton et al., 2008b.
- McCormick, R.E., Shughart, W.F., Tollison, R.D., 1984. The disinterest in deregulation. *American Economic Review* 74, 1075–1079.
- Mueller, D.C., 2003. *Public Choice III*. Cambridge University Press, Cambridge UK.
- Nitzan, S.I., 1994. Modelling rent-seeking contests. *European Journal of Political Economy* 10, 41–60.
- Parente, S.L., Prescott, E.C., 2000. Barriers to technological adoption and development. *Journal of Political Economy* 102, 298–321.
- Persson, T., Svensson, L., 1989. Why a stubborn conservative would run a deficit: Policy with time inconsistency preferences. *Quarterly Journal of Economics* 104, 325–345.
- Posner, R.A., 1975. The social costs of monopoly and regulation. *Journal of Political Economy* 83, 807–827 Reprinted in Congleton et al., 2008b.
- Stephan, J., Ursprung, H.W., 1998. The social cost of rent seeking when victories are potentially transient and losses final. In: Koch, K.-J., Jäger, K. (Eds.), *Trade, Growth, and Economic Policy in Open Economies*. Springer-Verlag, Berlin, pp. 369–380 (Reprinted in Congleton et al., 2008b).
- Tullock, G., 1967. The welfare costs of tariffs, monopolies, and theft. *Western Economic Journal* 5, 224–232 Reprinted in Congleton et al., 2008b.
- Tullock, Gordon, 1971. The cost of transfers. *Kyklos* 4, 629–643. Reprinted In: Buchanan, J.M., Tollison, R.D., Tullock, G., (Eds.), *Towards a Theory of the Rent-Seeking Society*. Texas A&M University Press, College Station, 1980, pp.269–282.